

3LM*





PORQUÊ?

PORQUE É SIMPLES E EFICAZ.

Monte um stand funcional e vistoso, sem precisar de complicar transportes ou comprometer o tempo dos seus recursos humanos. E claro, deixe a mala de ferramentas para outras ocasiões, a montagem é Tool Free.



Encaixes e clicks resolvem a montagem.



Consoante a dimensão, uma ou duas pessoas bastam para montar. Não são necessários recursos humanos especializados.



Para além das diferentes dimensões pode optar por:



Uma ou duas faces - backlight ou mobile stand;
Com ou sem luz - mobile stand.



Disponíveis acessórios para ligar, empilhar, fazer pontes, colocar prateleiras ou fixar ecrãs nos displays.





ÍNDICE

INFORMAÇÕES GERAIS

MONTAGEM	6
ILUMINAÇÃO	10
TRANSPORTE	12

MOBILE STAND BACKLIGHT

50 X 150 cm	16
85 X 200 cm	17
100 X 200 cm	18

MOBILE STAND DUPLA FACE

50 X 150 cm	24
100 X 250 cm	25
200 X 250 cm	26
300 X 250 cm	28
BALCÃO 100 X 100 cm	29



MONTAGEM

Através de conectores com o sistema “click-slide-lock”, poderá montar estas estruturas de forma rápida e sem complicações. Não requer ferramentas especiais, na verdade como o próprio nome indica, não requer qualquer tipo de instrumento! Para realizar a montagem não é necessário um recurso humano especializado, qualquer pessoa consegue levar a cabo a tarefa. Mais simples do que um Lego.

**Digitalize o QR Code para ver
vídeo de montagem.**











ILUMINAÇÃO

A iluminação pode ser feita através de réguas que encaixam nos perfis estruturais, ou com uma cortina de leds que preenche por completo uma das faces da estrutura.

A luz oriunda das réguas é mais intensa nas extremas e a cortina proporciona uma luminosidade difusa e mais homogênea por toda a superfície.

Família Tool Free Mobile Stand

Tool Free
BACKLIGHT

Cortina Led

Tool Free
DUPLA FACE

Régua Led

ou

Sem Luz





TRANSPORTE

Os Tool Free são comercializados com saco de transporte. Para além das pegas, possuem rodas e um pé de apoio para facilitar a deslocação. No interior, a compartimentação é em esponja densa que garante a arrumação correcta de todas as peças, reforçando a sua protecção.



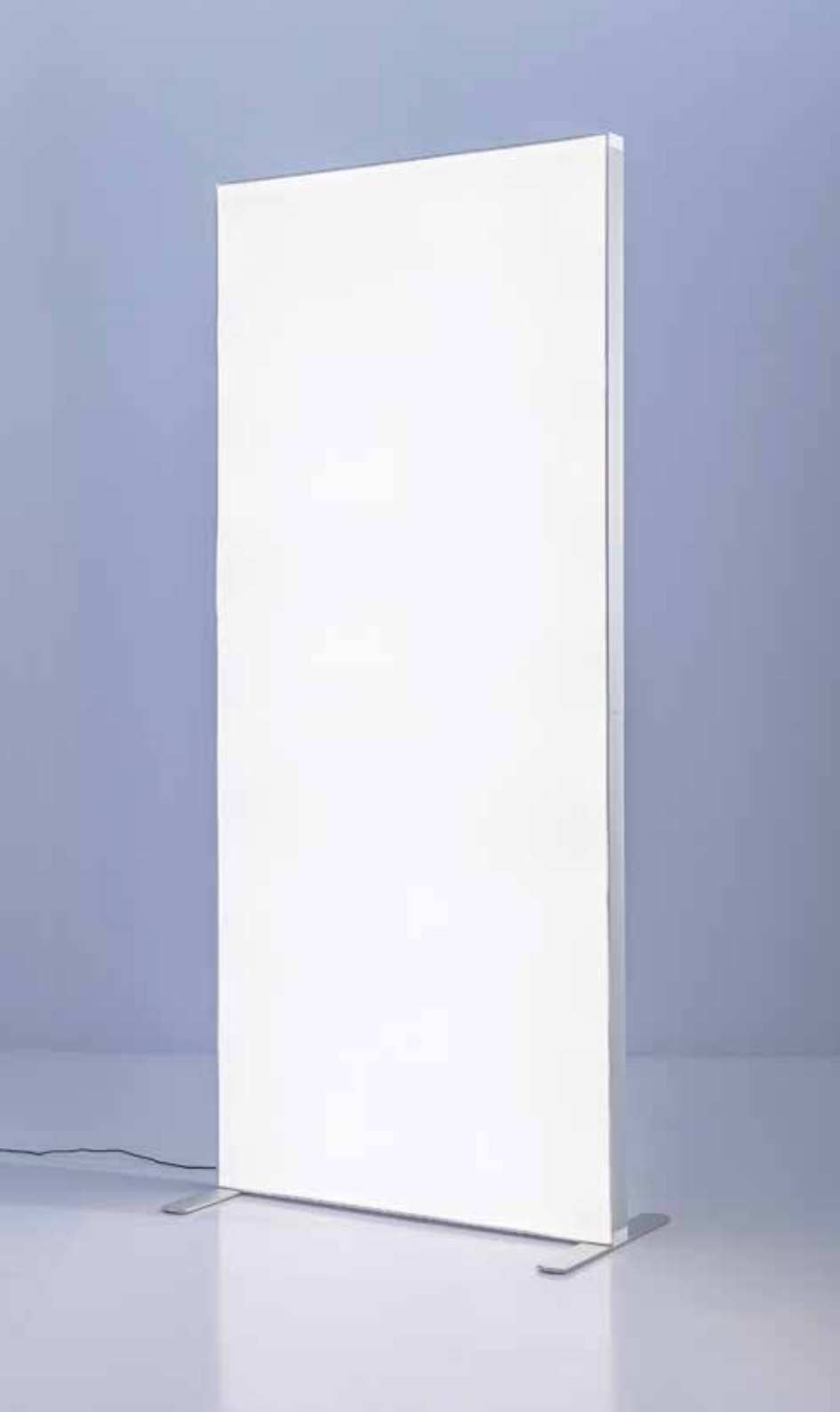



1

MOBILE STAND **BACKLIGHT**

50x150



BACKLIGHT

50 cm x 150 cm x 6 cm

Orientação:



Escala:



Montagem:



Tempo médio de montagem:

10 minutos

Material de Produção:

Têxtil

Acessórios:



TABELA TÉCNICA

CCT (k)	6100
Voltagem (v)	24
Potência (w)	21
LM/W	91
Total LM	1911
Área (m2)	0,75
Avg LM	2548
CU	0,85
EAV	2166
Fontes de alimentação 24v (w)	60
Fontes de alimentação 24v (amp)	3
Peso líquido (kg)	9



1



Digitalize para aceder às artes finais.

85x200



BACKLIGHT

85 cm x 200 cm x 6 cm

Orientação:



Escala:



Montagem:



Tempo médio de montagem:

10 minutos

Material de Produção:

Têxtil

Acessórios:



TABELA TÉCNICA

CCT (k)	6100
Voltagem (v)	24
Potência (w)	56
LM/W	91
Total LM	5096
Área (m2)	1,7
Avg LM	2998
CU	0,85
EAV	2548
Fontes de alimentação 24v (w)	96
Fontes de alimentação 24v (amp)	4
Peso líquido (kg)	11,09



Digitalize para aceder às artes finais.



100x200



BACKLIGHT

100 cm x 200 cm x 6 cm

Orientação:



Escala:



Montagem:



Tempo médio de montagem:

15 minutos

Material de Produção:

Têxtil

Acessórios:



TABELA TÉCNICA

CCT (k)	6100
Voltagem (v)	24
Potência (w)	84
LM/W	91
Total LM	7644
Área (m2)	2
Avg LM	3822
CU	0,85
EAV	3248,7
Fontes de alimentação 24v (w)	152
Fontes de alimentação 24v (amp)	4
Peso líquido (kg)	11,50



1



Digitalize para aceder às artes finais.



LEGENDA

- 01** Conector em L 60
- 02** Conector Recto 60
- 03** Pack União Backlight 200/250

PACK UNIÃO BACKLIGHT 200 / 250

2 BACKLIGHT

2 CORTINAS

2 TÊXTEIS/PRODUÇÕES

+



2 BACKLIGHT

2 CORTINAS

1 TÊXTIL/PRODUÇÃO





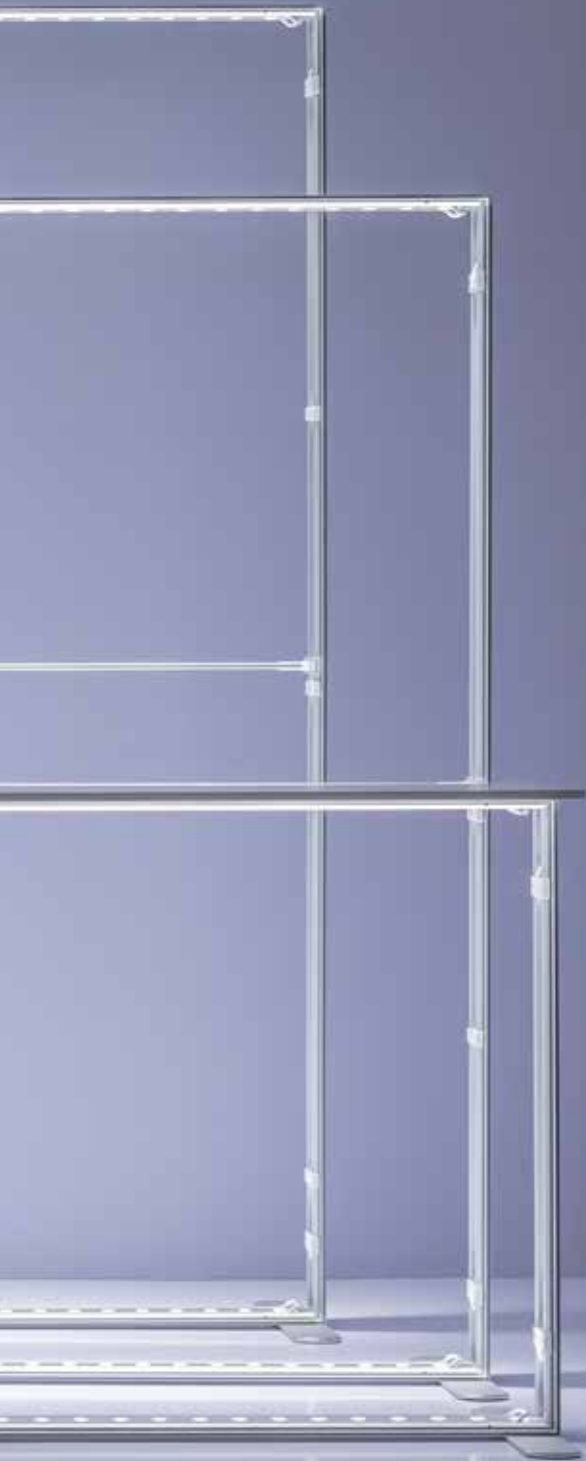

MOBILE STAND **DUPLA FACE**

50x150



DUPLA FACE

50 cm x 150 cm x 12 cm

Orientação:



Escala:

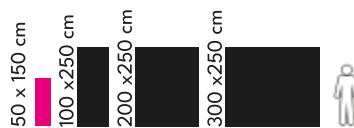

Montagem:

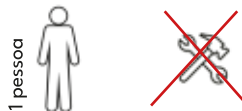

Tempo médio de montagem:

5 minutos

Material de Produção:

Têxtil

Acessórios:



TABELA TÉCNICA

CCT (k)	6800
Voltagem (v)	24
Potência (w)	42
LM/W	130
Total LM	5460
Área (m2)	0,75
Avg LM	7280
CU	0,80
EAV	5824152
Fontes de alimentação 24v (w)	60
Fontes de alimentação 24v (amp)	3
Peso líquido (kg)	9



Digitalize para aceder às artes finais.

100x250



DUPLA FACE

100 cm x 250 cm x 12 cm

Orientação:



Escala:

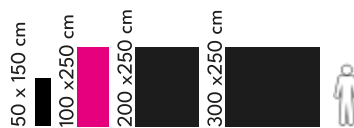

Montagem:

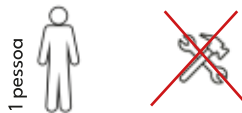

Tempo médio de montagem:

10 minutos

Material de Produção:

Têxtil

Acessórios:



TABELA TÉCNICA

CCT (k)	6800
Voltagem (v)	24
Potência (w)	90
LM/W	130
Total LM	11700
Área (m2)	2,5
Avg LM	4680
CU	0,80
EAV	3744
Fontes de alimentação 24v (w)	96
Fontes de alimentação 24v (amp)	4
Peso líquido (kg)	13,15



Digitalize para aceder às artes finais.



200x250



DUPLA FACE

300 cm x 250 cm x 12 cm

Orientação:



Escala:

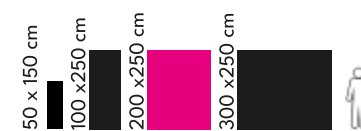

Montagem:



Tempo médio de montagem:
15 minutos

Material de Produção:
Têxtil

Acessórios:



TABELA TÉCNICA

CCT (k)	6800
Voltagem (v)	24
Potência (w)	180
LM/W	130
Total LM	23400
Área (m2)	5
Avg LM	4680
CU	0,80
EAV	3744
Fontes de alimentação 24v (w)	252
Fontes de alimentação 24v (amp)	11
Peso líquido (kg)	20,13



Digitalize para aceder às artes finais.



300x250



DUPLA FACE

300 cm x 250 cm x 12 cm

Orientação:



Escala:

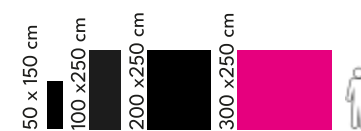

Montagem:

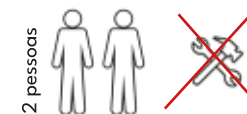

Tempo médio de montagem:
20 minutos

Material de Produção:
Têxtil

Acessórios:



TABELA TÉCNICA

CCT (k)	6800
Voltagem (v)	24
Potência (w)	270
LM/W	130
Total LM	35100
Área (m2)	7,5
Avg LM	4680
CU	0,80
EAV	3744
Fontes de alimentação 24v (w)	2x152
Fontes de alimentação 24v (amp)	6+6
Peso líquido (kg)	24,35



Digitalize para aceder às artes finais.



BALCÃO 100x100



DUPLA FACE

100 cm x 100 cm x 12 cm

Medida tampo:

105 cm x 30 cm x 1,5 cm

Escala:



Montagem:



Tempo médio de montagem:

10 minutos

Material de Produção:

Têxtil

TABELA TÉCNICA

CCT (k)	6800
Voltagem (v)	24
Potência (w)	45
LM/W	130
Total LM	5850
Área (m2)	1
Avg LM	5850
CU	0,80
EAV	4680
Fontes de alimentação 24v (w)	96
Fontes de alimentação 24v (amp)	4
Peso líquido (kg)	12



Digitalize para vídeo de montagem



Digitalize para aceder às artes finais.



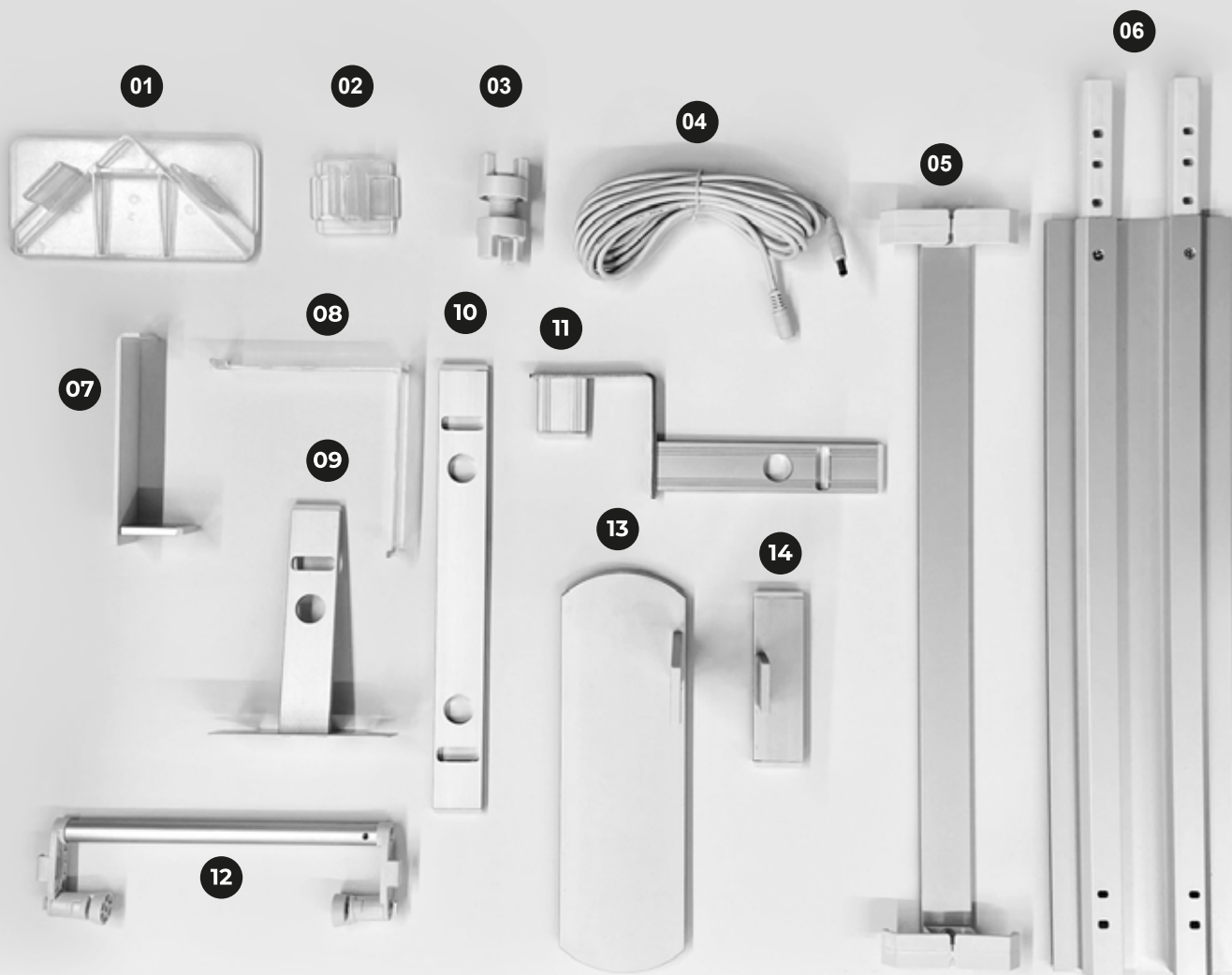

LEGENDA

01 Conector 90° 120 Exterior
02 Conector Recto em T 120
03 Conector Recto 120
04 Cabo Extensor 5M 120

05 Reforço Interior Ponte
06 Extensão Altura +50cm 120
07 Conector em T livre 120
08 Conector em L 120 /interior

09 Conector Empilhar 120
10 Conector Meio Empilhar 120
11 Conector Ponte Livre 120
12 Acessório Pendurar Prateleira

13 Meio Pé
14 Mini Pé

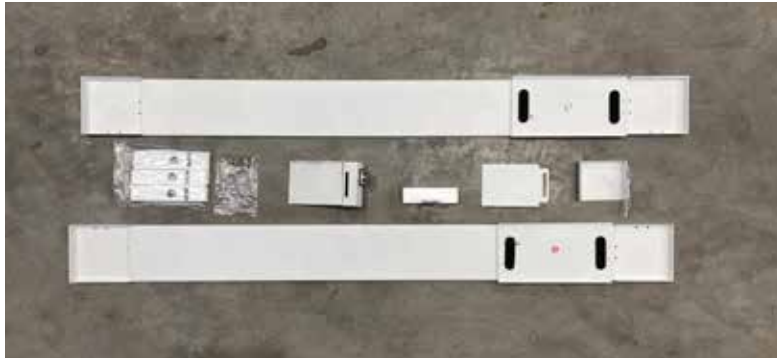

DOOR KIT

100X250 cm

Complemento apenas disponível apenas para o modelo
TOOL FREE MOBILE DUPLA FACE 100X250 cm.

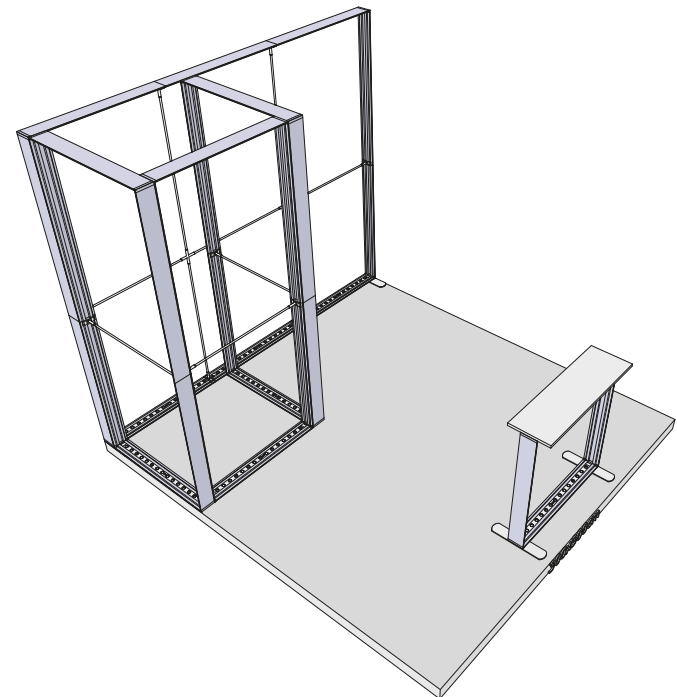

Digitalize para vídeo de montagem

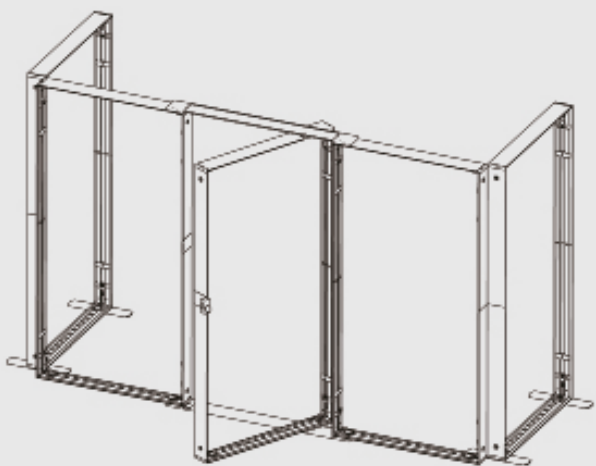
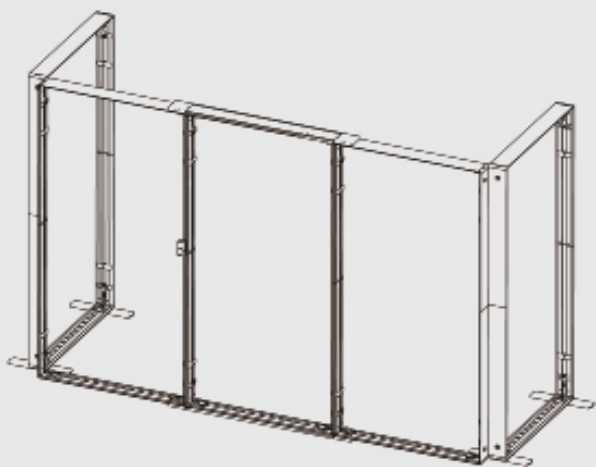

OPÇÃO A

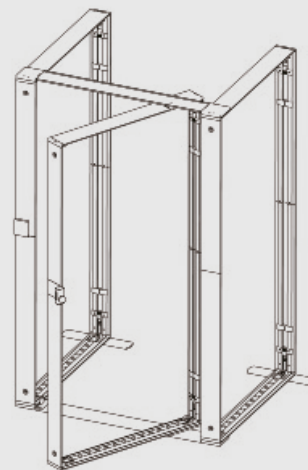
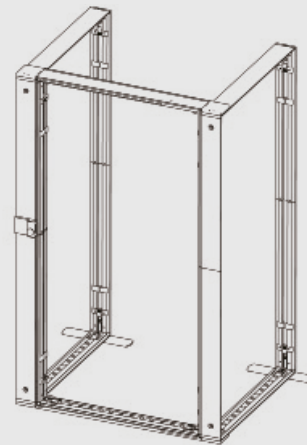

OPÇÃO B



PRATELEIRA

100X250 cm

Complemento apenas disponível apenas para o modelo
TOOL FREE MOBILE DUPLA FACE 100X250 cm.



Digitalize para vídeo de montagem

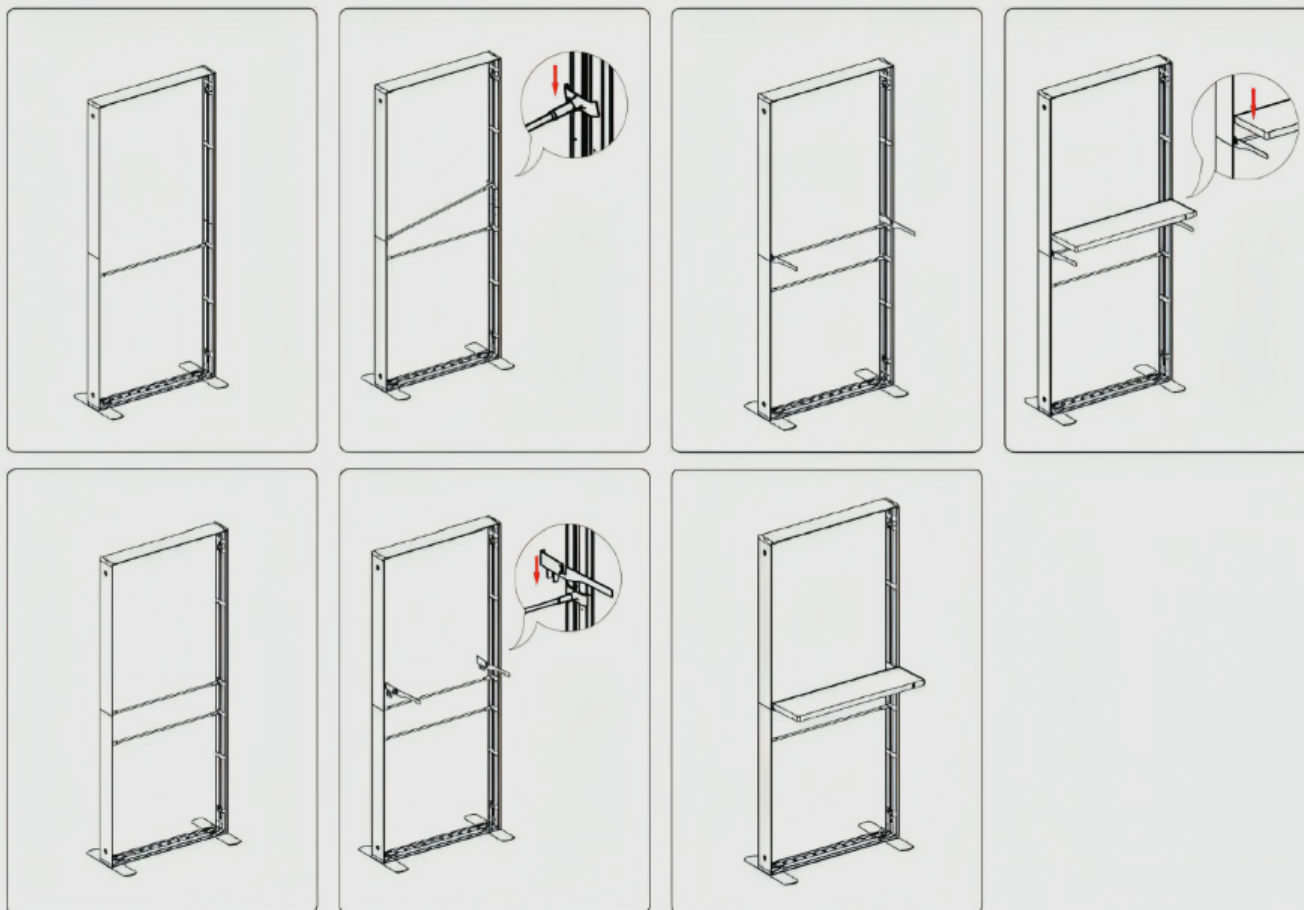



SUPOORTE DE MONITOR

100X250 cm

Complemento apenas disponível apenas para o modelo
TOOL FREE MOBILE DUPLA FACE 100X250 cm.



Digitalize para vídeo de montagem

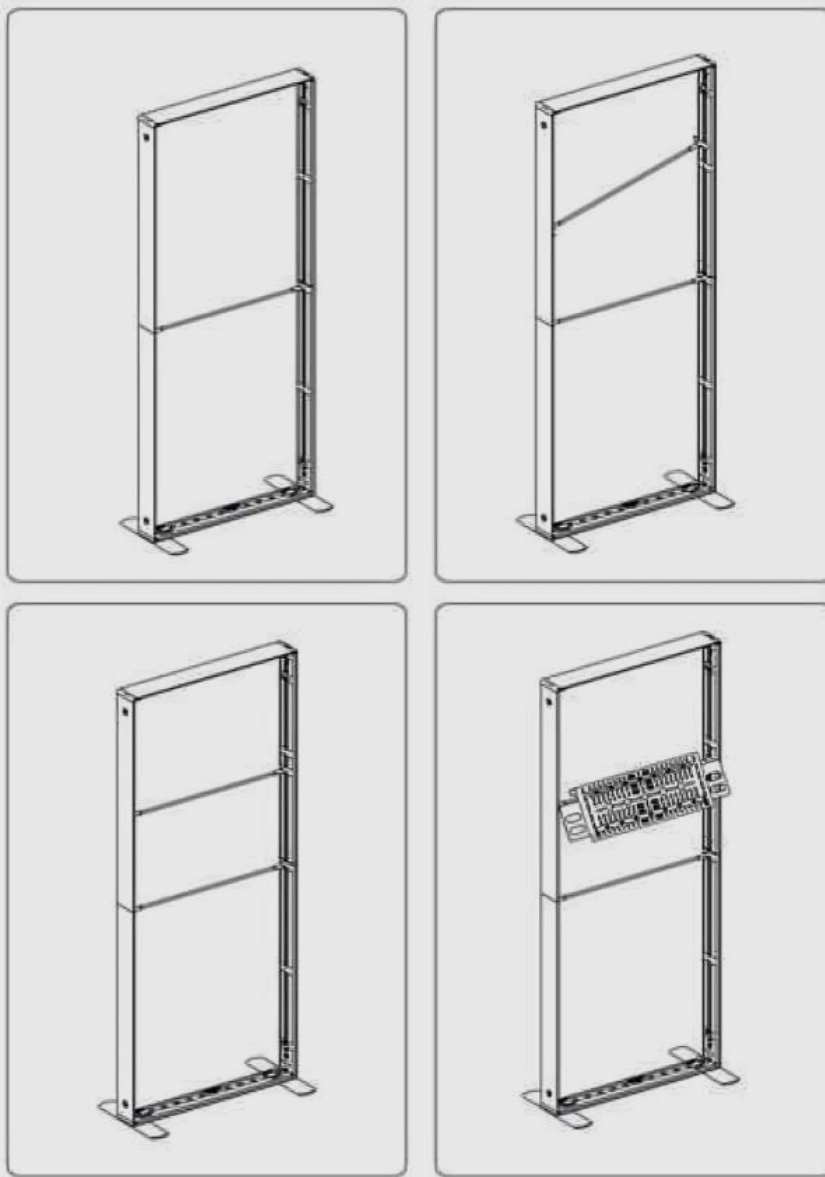

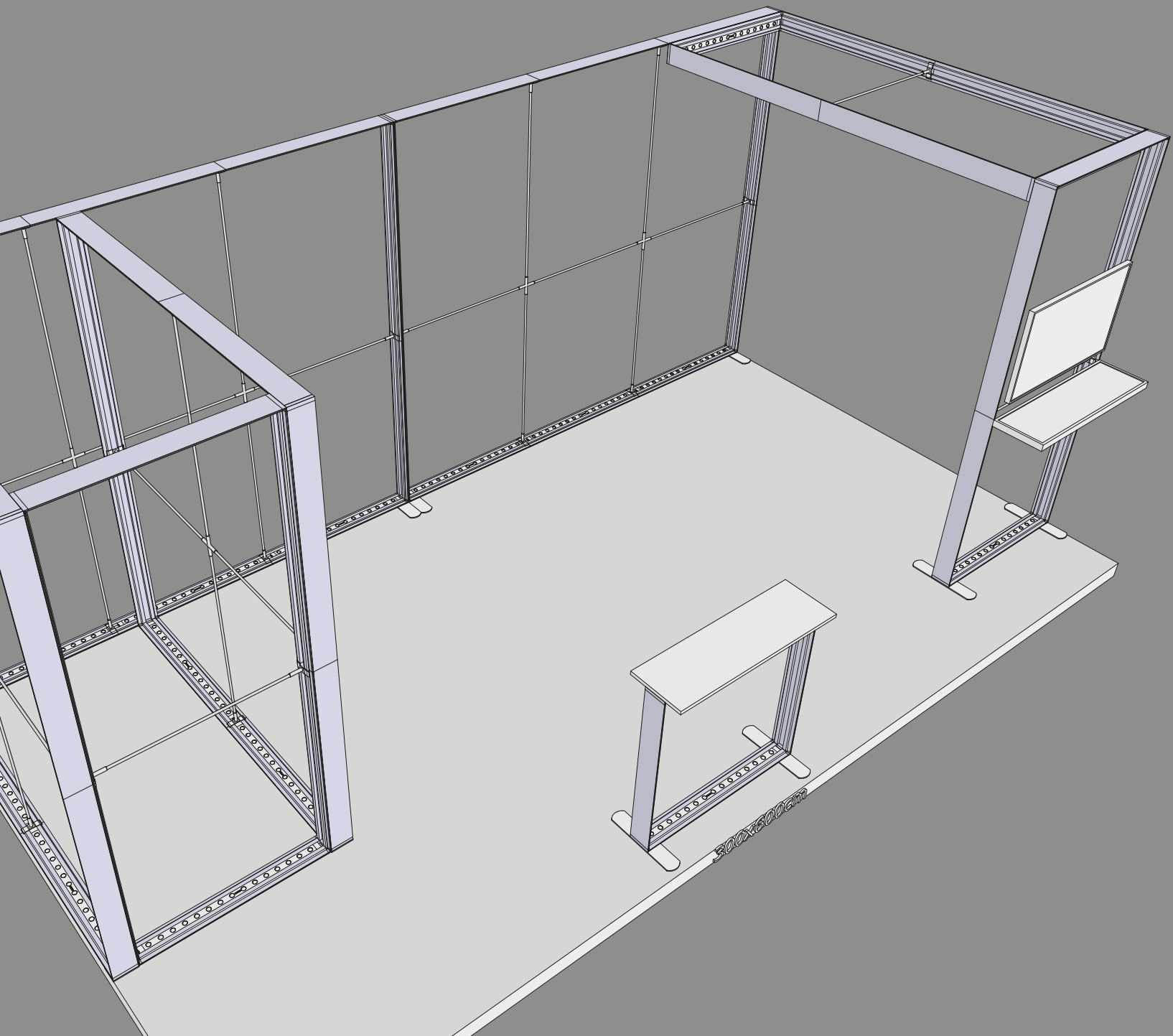

inspire-se | sugestões de montagem

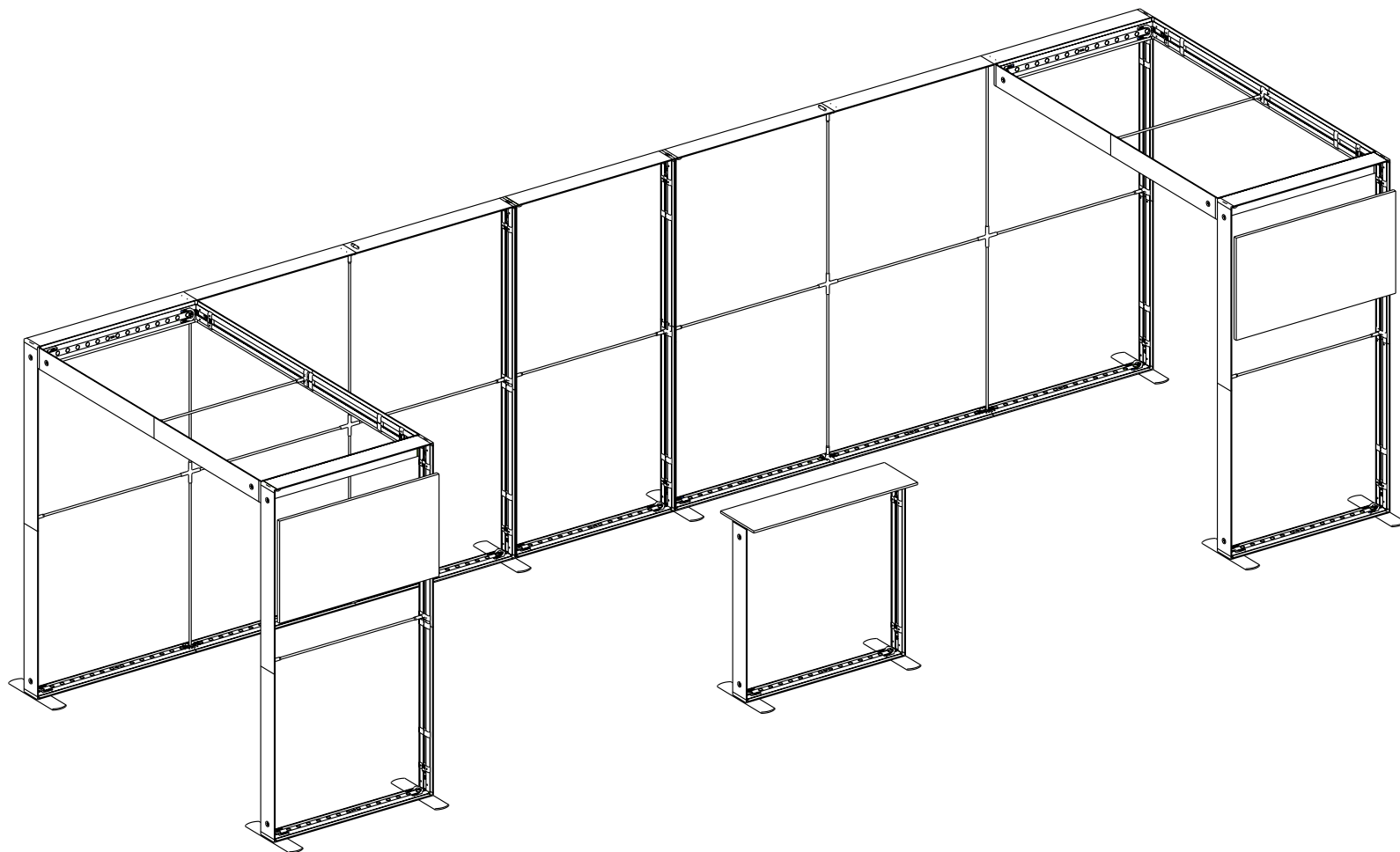

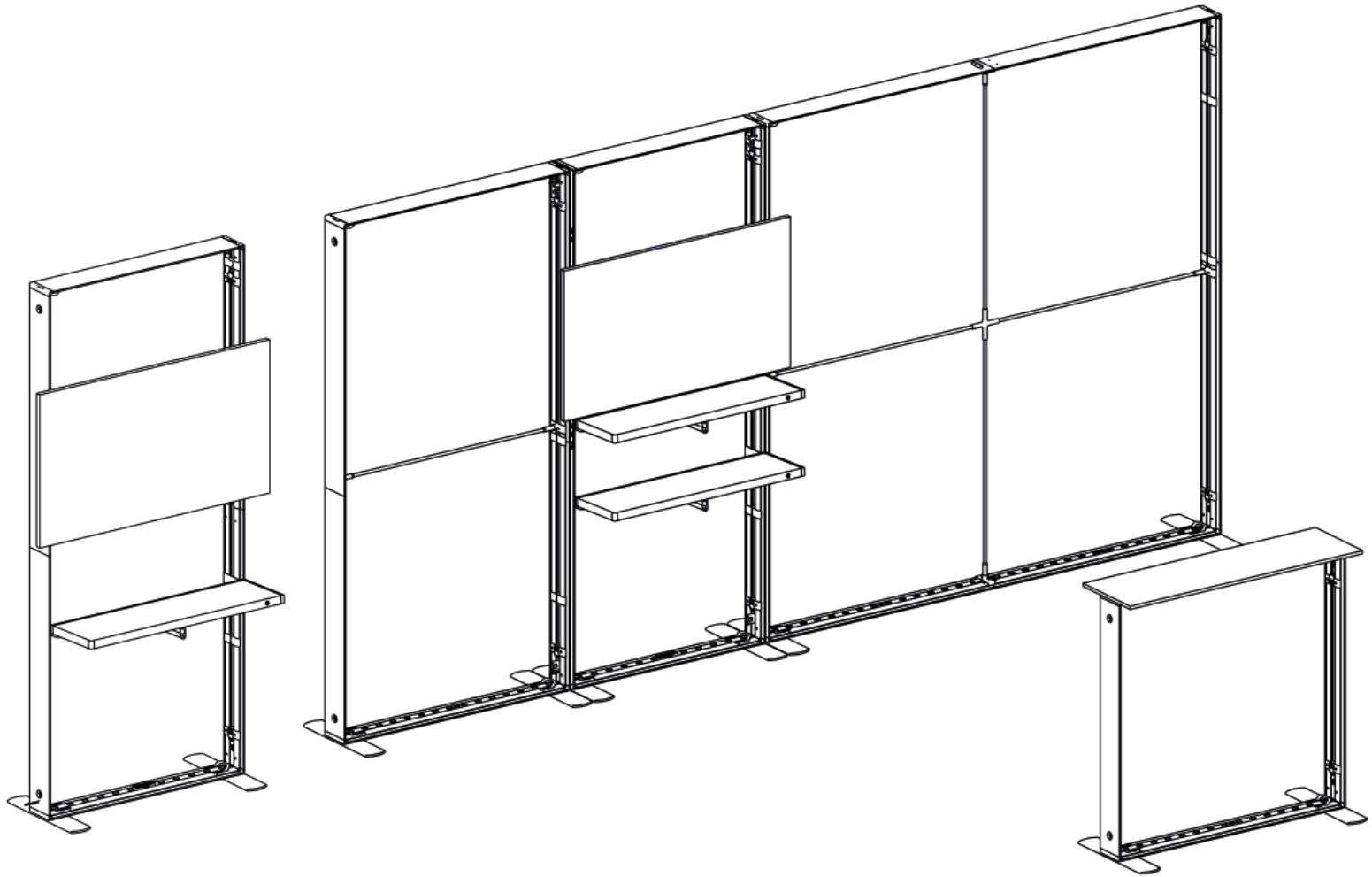

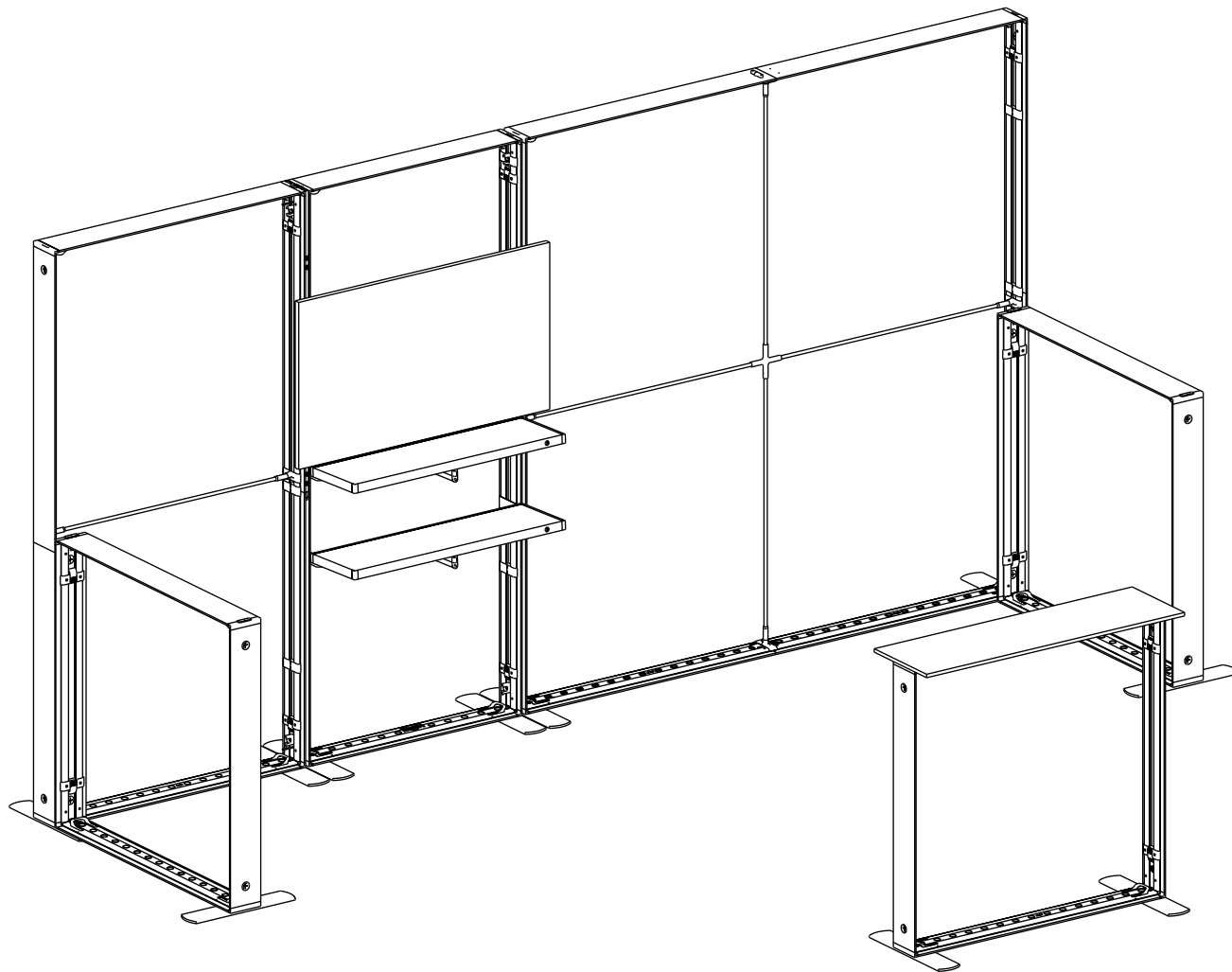

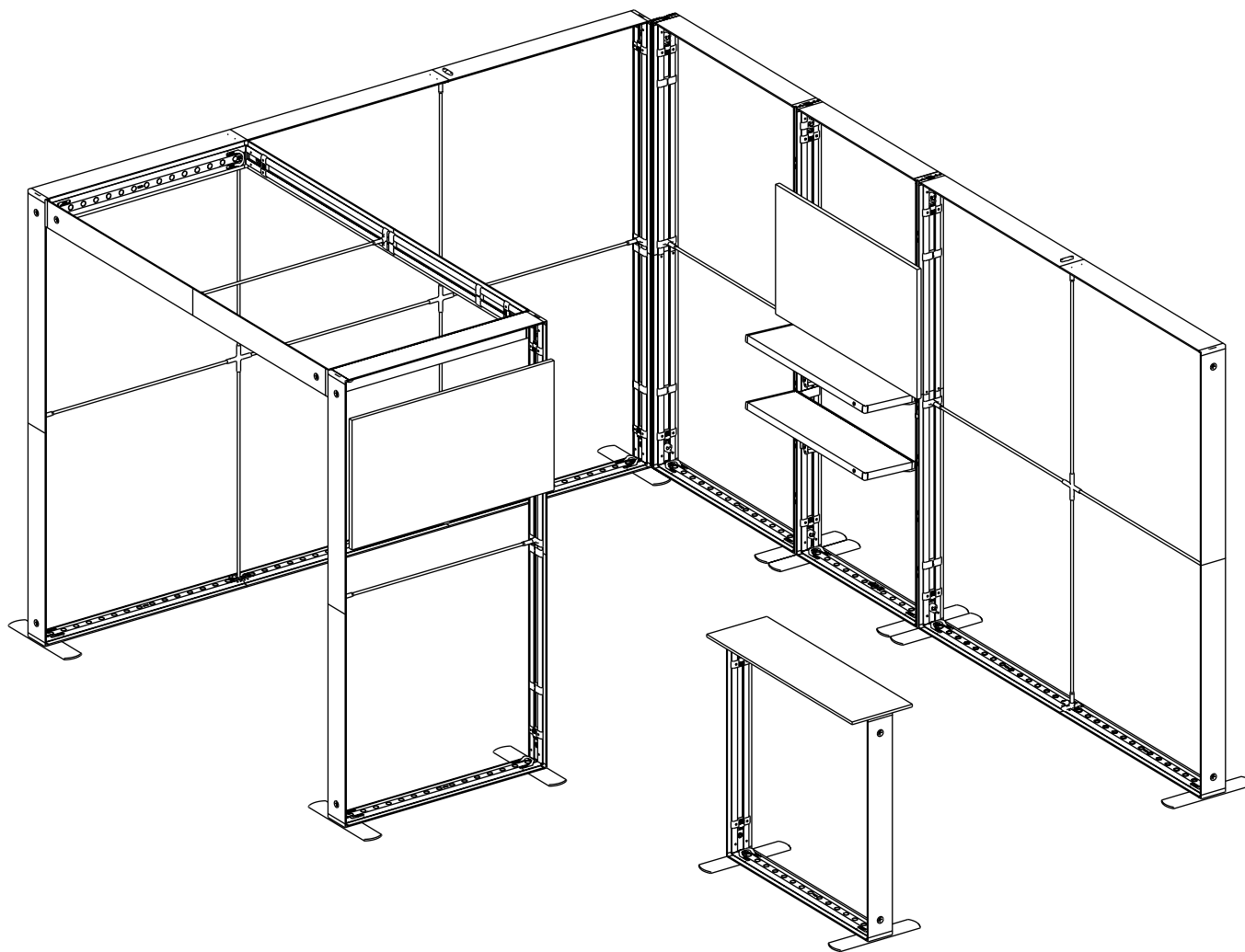

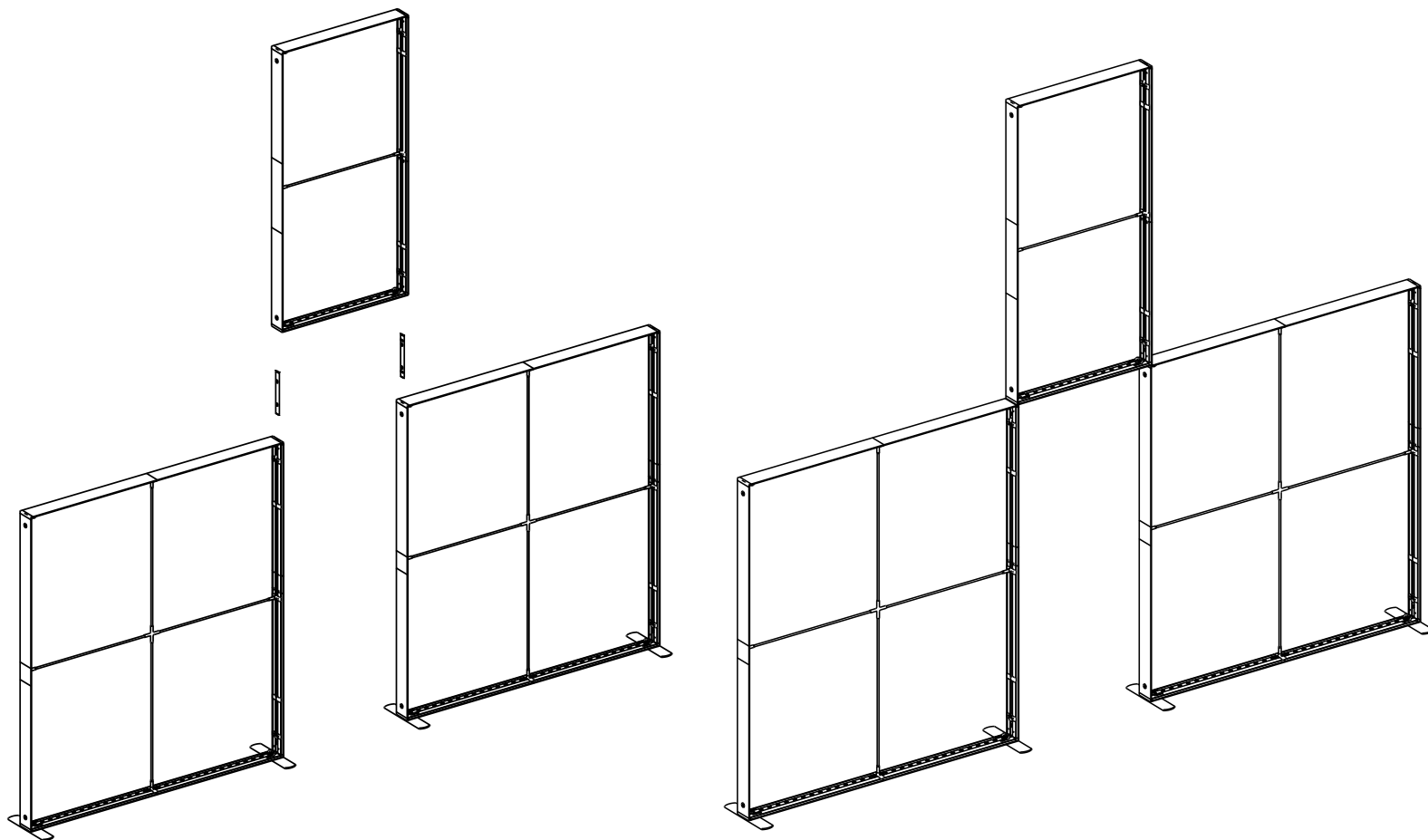

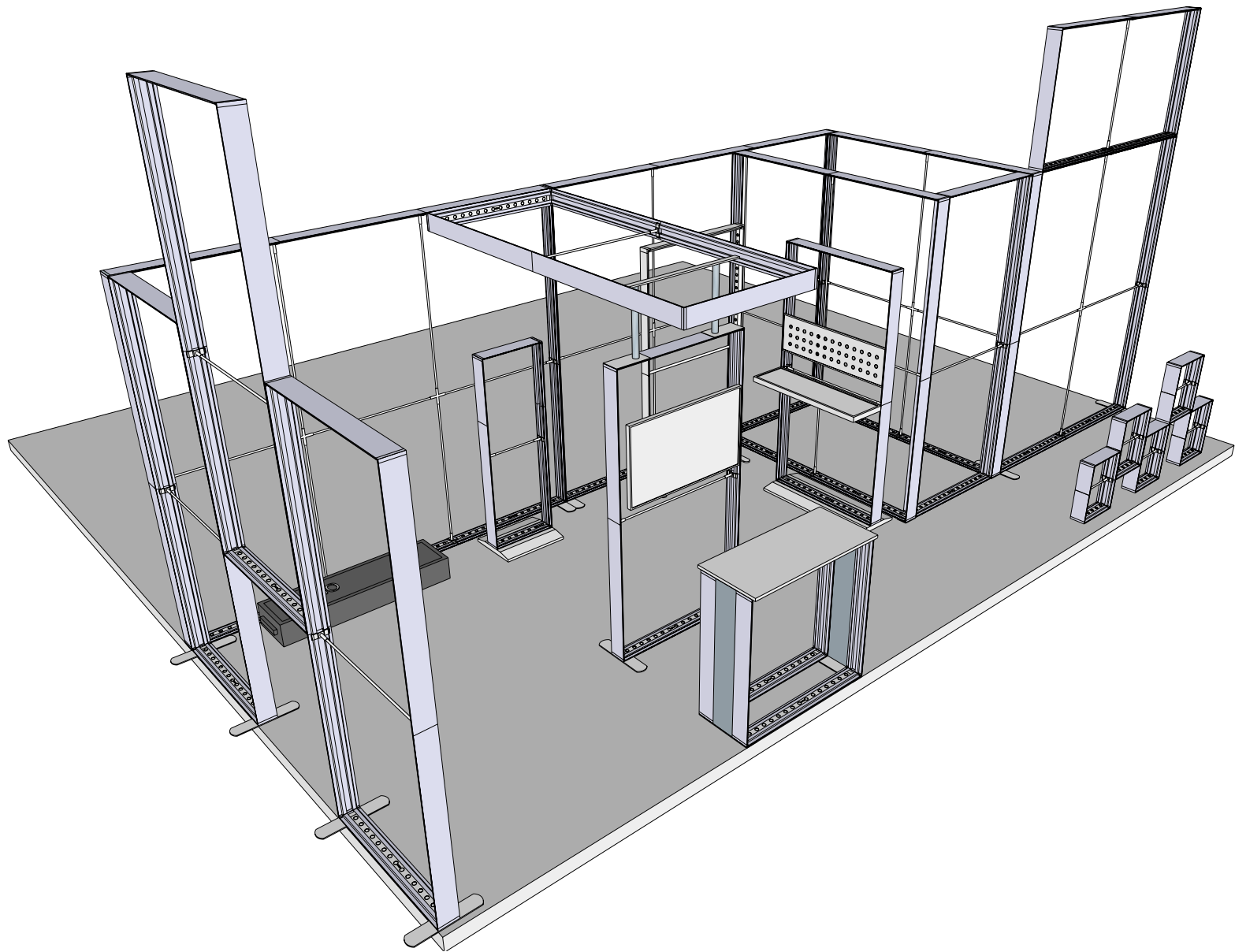



ANEXO CERTIFICADO



LIGHT STRIPE CE-EMC



SEGO 116634 LED LIGHTS CE-EMC



SEGO LIGHTBOX ROHS CERTIFICATE 116634



SEGO MOBILE LIGHT BOX CE-EMC



SEGO MOBILE LIGHT BOX CE-LVD



SEGO MOBILE LIGHT BOX ROHS



SEGO MOBILE LIGHTBOX 116634 CE-EMC



SEGO MOBILE LIGHTBOX 116634 CE-LVD

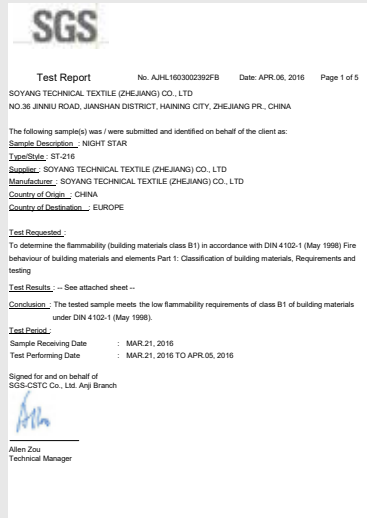

SEGO60 BACKLIT BLOCKOUT FABRIC
FLAMMABILITY TESTING REPORT SGS



SEGO60 LED CURTAIN CE

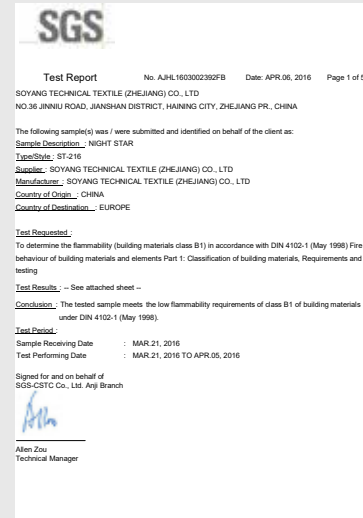

ST-216 SGS

3LM*
3lm.pt

A 3LM reserva o direito de modificar este documento ou os produtos nele contidos, sem aviso prévio.
Todas as informações contidas neste documento, são fornecidas e são meramente orientativas e não vinculativas.
A 3LM não tem qualquer responsabilidade sobre a informação prestada neste documento, nem sobre a consequência do seu uso.

3LM PUBLICIDADE E IMAGEM
Rua 4 de julho, arm 10
3025-010 Portugal

(+351) 239 983 322
3lm@3lm.pt

3lm.pt